

## Product Datasheet - WSL 6050F1 Series - Fixed lights

The Wrightstyle 6050F1 series range of glazing systems provides an unlimited number of fenestration options. Utilising a range of high quality steel profile shapes it provides countless possibilities for fire insulated applications.

Multiple configurations of doors, screens and windows can be produced from Wrightstyle's vast range of profiles; an integral part of Wrightstyle's total glazing system solutions.

Profiles are produced from cold rolled hollow sections, manufactured to strict production tolerances from 2mm steel punched and filled with a unique infilling material to provide an enhanced thermal barrier.

Modern manufacturing processes allows us to produce steel glazing systems, which combine the inherent strength and durability of steel, with the aesthetic qualities normally associated with aluminium systems. The following pages provide a brief overview of the capabilities of the systems.

- Competitively priced
- Multiple framing options
- High quality sendzimir galvanising
- Internal & external surface protection
- 2mm steel thickness
- Tested to 60 mins fire rating
- Multiple profile options
- Multiple tape or gasket glazing options
- Fully enclosed profile design for ease of fabrication and superior flat finish
- Can be supplied in bar length or fully fabricated

### WSL 6050F1 Series - Profile Configuration (colours shown for clarity)

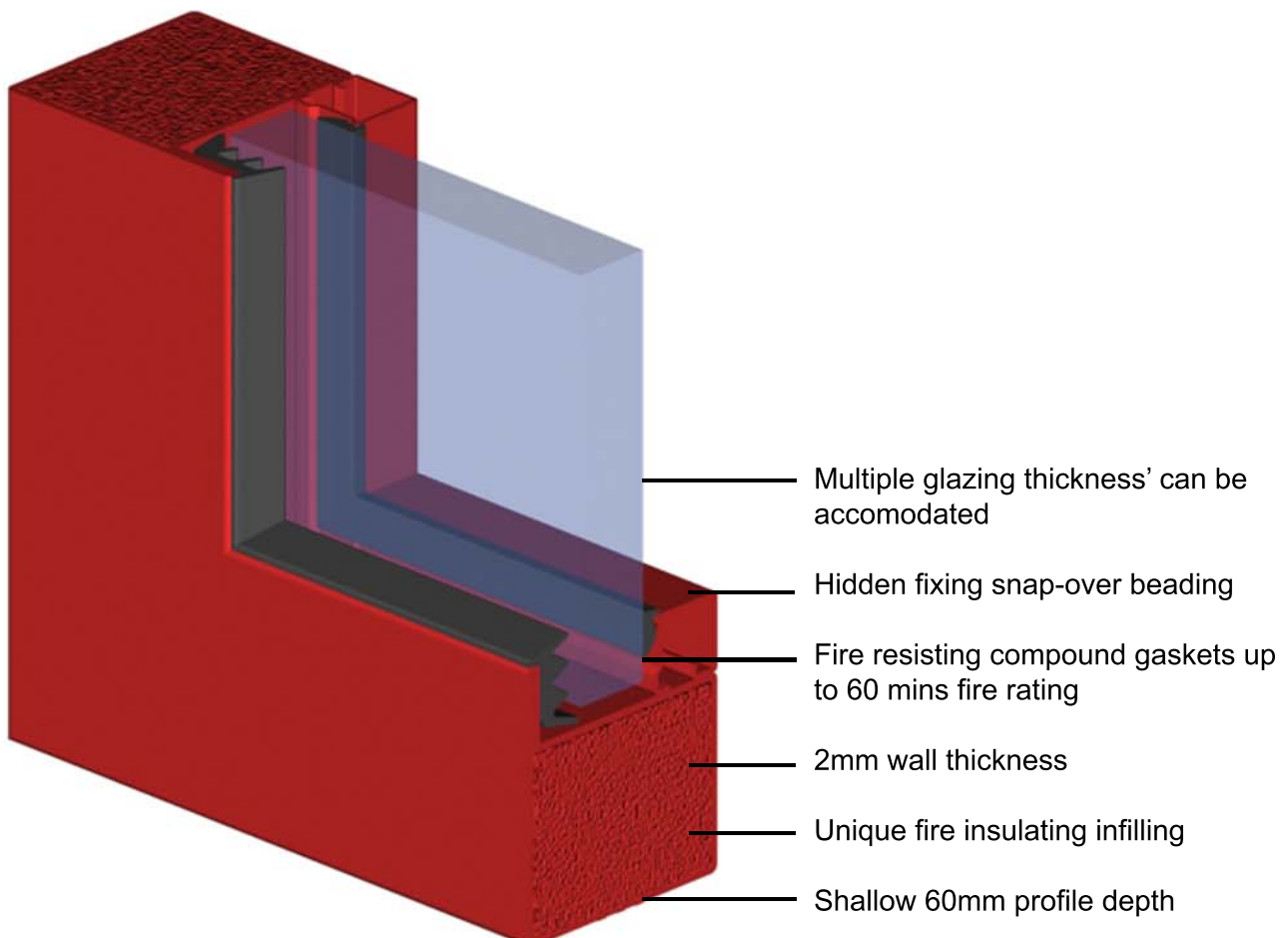

## Product Datasheet - WSL 6050F1 Series - Fixed Lights

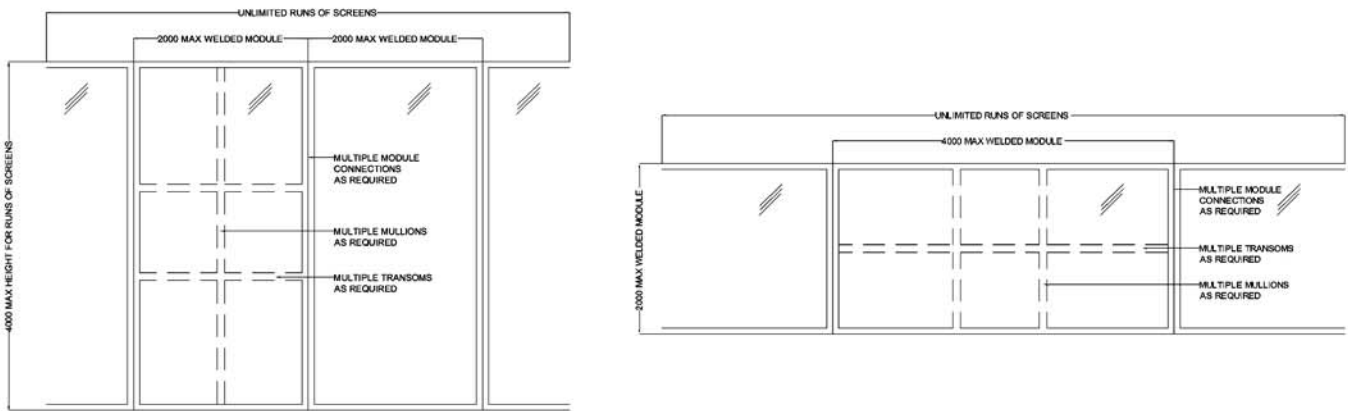

### WSL 6050F1 series permissible configurations 30 & 60 mins integrity and insulation

Framing may be supplied in multiple configurations to suit the application, with the following conditions:

- Maximum individual welded element size of 4000mm x 2000mm (in either aspect). Elements may be connected together to form unlimited runs of screens.
- Structural fixings at nominally 500mm centres max, with module joins at 300mm centres max.
- Tape or gasket glazing up to 60 mins.
- Size limitations shown consider both fire test data and maximum powder coating line size.
- Wrightstyle doors & windows may be incorporated into the framing configuration to the required timescale.

Directions:

Plot your required frame size on the chart below. Current test data allows for any individual welded element frame size within the blue areas. These elements may be connected together to make runs of screens, and may also be sub divided using additional mullions / transoms.

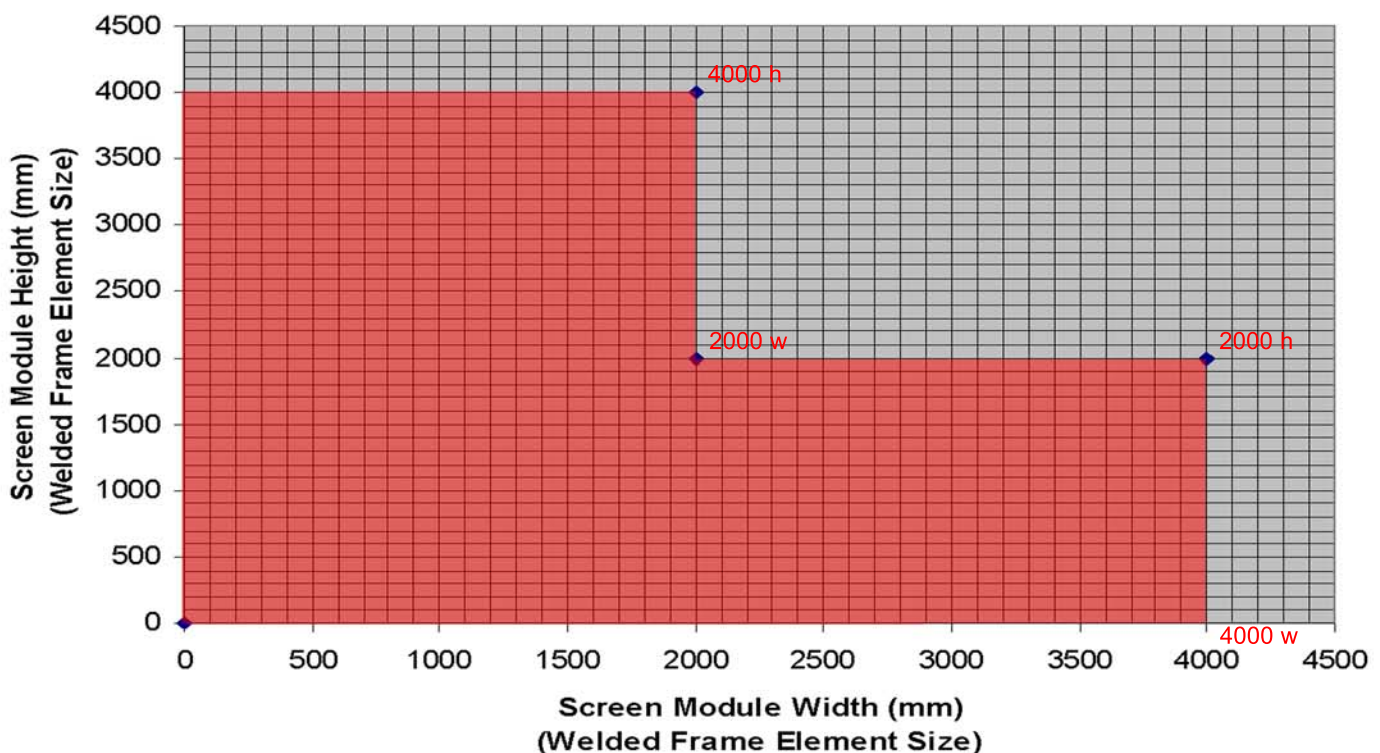

Note: Additional conditions may apply. Please check test data

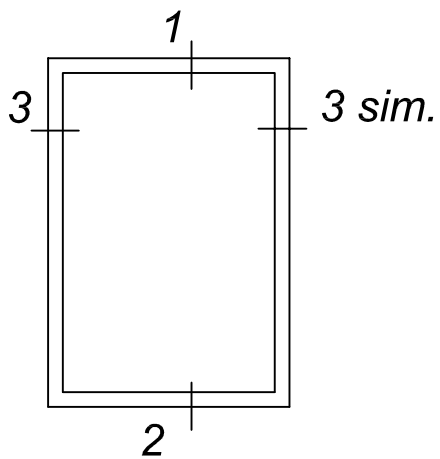

1

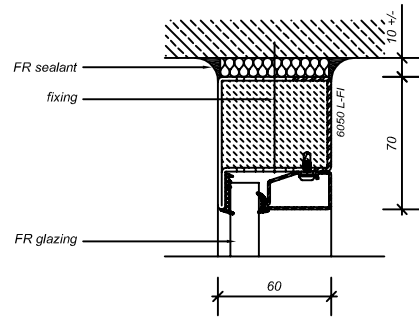

3 sim.

2

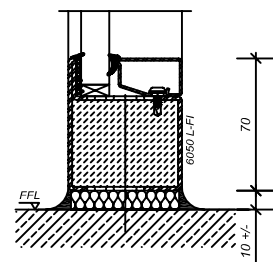
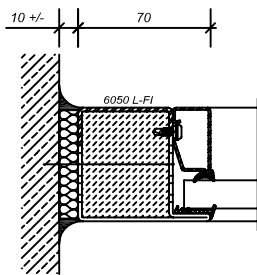

**WRIGHTSTYLE 6050 SERIES  
FIXED WINDOW**

*Elevation NTS/details 1:4 @ A4*

Approved options:

- With or without mullions and transoms